



VS Series

Model 01 Storage Systems



The new **VS Series Storage Systems** that can be used in liquid nitrogen, oxygen or argon service is now offered by Chart in a wide range of sizes for applications requiring operating pressures at 175 and 250 psig (*12 and 17 bar*) as standard. Other pressures available upon request. Chart offers this equipment designed in accordance with ASME code.

Our composite insulation system gives you the competitive edge with high thermal performance, extended hold times, low life-cycle costs and light weight to reduce operational and installation costs. Chart leads the industry with an innovative modular piping system designed for performance, durability and low maintenance.

Benefits:

- ❖ Piping modules designed for ease-of-access to all operational control valves with stainless steel interconnecting piping to minimize the number of connections, reducing maintenance and cost of ownership
- ❖ Component selection to improve operational performance -- Combination Pressure Building/Economizer Regulator for easy pressure adjustment and extended Bonnet Bronze Control Valves for ease of operation
- ❖ High performance safety system with dual relief valves and rupture disks supplied as a standard
- ❖ New, innovative Vertical Fin Pressure Building System improves performance, while reducing frost and ice build-up to further reduce your maintenance costs
- ❖ Backed by an industry-leading warranty

VS Series

Model 01 Storage Systems

Model	Gross Capacity		Nominal Capacity		Working Pressure*		Diameter		Height		Weight**		NER % /day in O ₂
	Gal	Liters	Gal	Liters	psig	bar	in	mm	in	mm	lbs.	Kg	
VS 525NC	540	2,044	491	1,859	250	17.2	66	1,676	102	2,591	4,000	1,814	.55
VS 900NC	929	3,517	845	3,197	250	17.2	66	1,676	134	3,404	5,100	2,313	.35
VS 1500NC	1,585	5,999	1,509	5,714	250	17.2	66	1,676	188	4,763	7,400	3,357	.30
VS 3000NC	3,158	11,995	3,037	11,495	175	12.1	86	2,184	228	5,791	12,600	5,715	.25
VS 6000NC	6,075	22,997	5,841	22,112	250	17.2	86	2,184	382	9,703	24,500	11,113	.15
VS 9000NC	9,447	35,761	9,084	34,387	175	12.1	114	2,896	347	8,814	33,000	14,970	.10
VS 11000NC	11,480	43,457	11,145	42,183	250	17.2	114	2,896	406	10,312	39,500	17,920	.10
VS 13000NC	13,513	51,152	13,119	49,661	175	12.1	114	2,896	465	11,811	46,700	21,190	.10
VS 15000NC	15,545	58,844	15,093	57,133	250	17.2	114	2,896	525	13,335	53,700	24,360	.10

* 400, 500 psig tanks are available upon request
(NER) = Nominal Evaporation Rate

** Weights are for ASME designs

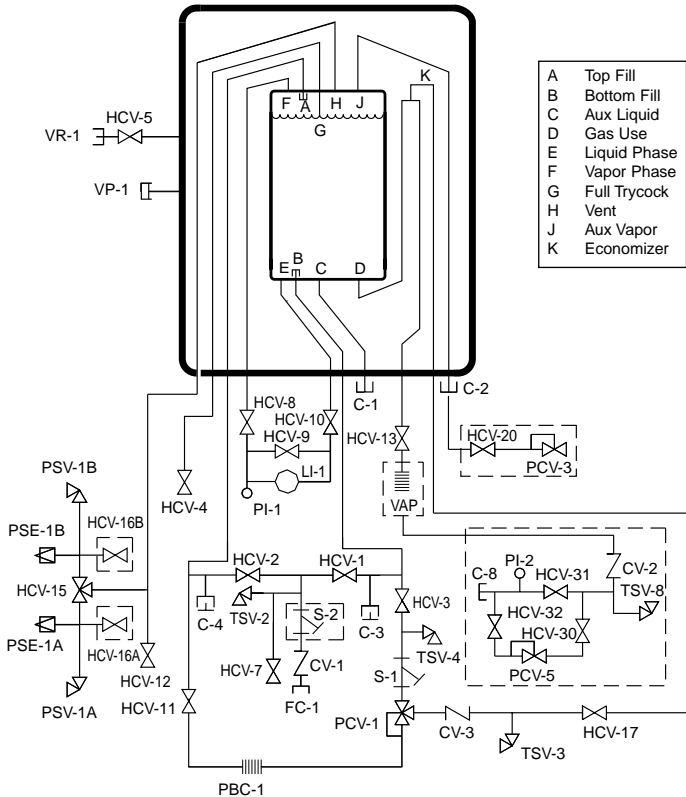

Nomenclature

C-1	Connection, Aux Liquid	S-1	Strainer, Pressure Building
C-2	Connection, Aux Vapor	TSV-2	Thermal Safety Valve, Fill
C-3	Connection, Secondary Aux Liq.	TSV-3	Thermal Safety Valve, Economizer
C-4	Connection, Secondary Aux Vapor	TSV-4	Thermal Safety Valve, PB Circuit
CV-1	Check Valve, Fill	VP-1	Vacuum Port
CV-3	Check Valve, Economizer	VR-1	Vacuum Readout, Outer Vessel
FC-1	Connection Fill		
HCV-1	Valve, Bottom Fill		
HCV-2	Valve, Top Fill		
HCV-3	Valve, PB Inlet		
HCV-4	Valve, Full Trycock		
HCV-5	Valve, Vacuum Gauge Tube		
HCV-7	Valve, Fill Line Drain		
HCV-8	Valve, LI-1 Vapor Phase		
HCV-9	Valve, LI-1 Equalization		
HCV-10	Valve, LI-1 Liquid Phase		
HCV-11	Valve, PB Outlet		
HCV-12	Valve, Vapor Vent		
HCV-13	Valve, Product Supply		
HCV-15	Valve, Safety Relief Selector		
HCV-17	Valve, Economizer		
LI-1	Level Indicator, Inner Vessel		
PBC-1	Pressure Building Coil, Inr. Ves.		
PCV-1	Pressure Control Valve		
PI-1	Pressure Indicator, Inner Vessel		
PSE-1A	Pressure Safety Element, Inr Ves		
PSE-1B	Pressure Safety Element, Inr Ves		
PSV-1A	Pressure Safety Valve, Inr Ves		
PSV-1B	Pressure Safety Valve, Inr Ves		
S-1	Strainer, Pressure Building		
TSV-2	Thermal Safety Valve, Fill		
TSV-3	Thermal Safety Valve, Economizer		
TSV-4	Thermal Safety Valve, PB Circuit		
VP-1	Vacuum Port		
VR-1	Vacuum Readout, Outer Vessel		

NOTE: Optional valves (not shown)

HCV-18	Valve, Liquid Withdrawal (From C-1)
HCV-19	Valve, Vapor Return (From C-2)
HCV-21	Valve, Sec Aux Liquid (From C-3)
HCV-22	Valve, Sec Aux Vapor (From C-4)

**Dashed lines represent optional components*

C-8	Connection, Customer Housetline
CV-2	Check Valve, Housetline
HCV-16A	Valve, Relief Line Purge
HCV-16B	Valve, Relief Line Purge
HCV-20	Valve, Economizer Vent
HCV-30	Valve, Inlet Housetline
HCV-31	Valve, Bypass Housetline
HCV-32	Valve, Outlet Housetline
PCV-3	Pressure Control Valve, Econo Vent
PCV-5	Pressure Control Valve, Housetline
PI-2	Pressure Indicator, Housetline
S-2	Strainer, Fill
TSV-8	Thermal Safety Valve, Housetline
VAP	Vaporizer, Product Withdrawal



Chart Storage Systems Division, 3505 County Road 42 West, Burnsville, MN 55306-3803

Web: www.chart-ind.com; E-mail: storagesystems@chart-ind.com

US: 800-400-4683, FAX: 800-232-9683; Worldwide: 952-882-5090; FAX: 952-882-5008

Chart Europe GmbH: +49 (0)212-700 570, FAX: +49 (0)212-700 577; Chart Asia Inc.: 65-838-5209, FAX: 65-235-3680